

**TOWN OF TIMNATH, COLORADO
RESOLUTION NO. 19, SERIES 2025**

**A RESOLUTION APPROVING A TEMPORARY EASEMENT AGREEMENT WITH
THE LARIMER COUNTY CLERK AND RECORDER FOR THE PLACEMENT OF A
BALLOT BOX AT 4750 SIGNAL TREE DRIVE**

WHEREAS, the Town Council of the Town of Timnath (“Town”) pursuant to C.R.S. § 31-15-103, has the power to pass resolutions; and

WHEREAS, attached hereto is a Temporary Easement Agreement (the “Easement Agreement”); and

WHEREAS, the Town of Timnath (“Grantor”), the owner of certain real property located on Exhibit A map (the “Property”), has agreed to grant an easement on a portion of said Property to the Larimer County Clerk and Recorder (“Grantee”); and

WHEREAS, the easement granted will be for the purposes of installing and maintaining a ballot drop box (the “Drop Box”), which is necessary for the public good and in the best interest of the community; and

WHEREAS, the granting of a Temporary Easement will allow Grantee to carry out the Project; and

WHEREAS, the Town Council is familiar with the Easement Agreement and finds it to be in the best interest of the Town, its residents, and the general public.

NOW, THEREFORE, BE IT RESOLVED BY THE TOWN COUNCIL OF THE TOWN OF TIMNATH, COLORADO AS FOLLOW:

Section 1. Approval

The Easement Agreement is hereby approved in substantially the form as attached hereto, subject to technical or otherwise non-substantive modifications, as deemed necessary by the Town Manager in consultation with the Town Clerk, Public Works Director, Town Engineer, Legal Counsel, and other applicable staff or consultants.

INTRODUCED, MOVED, AND ADOPTED BY THE TOWN COUNCIL OF THE TOWN OF TIMNATH, ON MARCH 11, 2025.

TOWN OF TIMNATH, COLORADO



Robert Axmacher, Mayor

ATTEST:



Milissa Peters-Garcia, MMC
Town Clerk



EXHIBIT A

TEMPORARY EASEMENT AGREEMENT

TEMPORARY EASEMENT AGREEMENT

This Temporary Easement Agreement (the "Agreement"), effective on March 11 2025, is made by and between **Town of Timnath** ("Town") and the **Larimer County Clerk and Recorder**, ("Clerk") (collectively the "Parties").

WHEREAS, Colorado state law requires the placement of ballot drop boxes in Larimer County to serve as a place where ballots can be deposited during elections; and

WHEREAS, Town is the owner in fee of the property at 4750 Signal Tree Dr. ("Property"), which the Parties agree is a community-based location that is convenient for voters to drop off their ballots; and

WHEREAS, Clerk desires to install and maintain a ballot drop box ("Drop Box") on the Property in the area generally depicted on Exhibit A ("Easement Area"), and Town desires to have a Drop Box in the Easement Area for the convenience of area voters.

NOW THEREFORE, for the mutual benefits received and to be received, Town and County agree as follows:

1. Grant of Temporary Easement: Town hereby grants to Clerk a non-exclusive temporary easement (the "Easement") on, over, under, and across the Easement Area for purposes of:
 - a. Locating, installing, constructing, using, operating, maintaining, inspecting, repairing, altering, removing and replacing a Drop Box and security camera equipment as generally depicted and described on Exhibit "A".
2. No Interference: During the term of this Agreement, Town shall not make or allow alterations to the Easement Area, or otherwise make or allow interference with the Easement purposes stated herein.
3. Term. The Easement shall continue until mutually terminated or a party unilaterally terminates by giving the other party 365 calendar days advanced written notice.
4. Mitigation/Restoration. Clerk will repair and restore the Easement Area as needed to account for any damage or disruption caused by installation of the Drop Box. Within 180 days of this Easement terminating, Clerk will remove the Drop Box and repair and restore the Easement Area to a level comparable to its original condition.
5. Miscellaneous.
 - a. Nothing herein shall be deemed a waiver by the Clerk or Town of any legal limitations or immunities provided by law, including the Colorado Governmental Immunity Act, C.R.S. section 24-10-101 et seq., as amended, and the Constitution of the State of Colorado, Article XI, Section 1.
 - b. The Clerk contact for this Agreement is: Dirk Bruley
 - c. The Town contact for this Agreement is: Earl Smith

IN WITNESS WHEREOF, the Parties have executed this Temporary Easement Agreement as of the date accompanying their signatures below.

Larimer County Clerk and Recorder

By: Tina Harris 3/00/2025
Tina Harris Date
Clerk and Recorder

Town of Timnath

By: Earl Smith 3/12/2025
DocuSigned by:
2589243BADFA679... Earl Smith Date
Town Engineer and Facilities Manager

Exhibit A – Town of Timnath

24 Hour Ballot Drop Box Description:

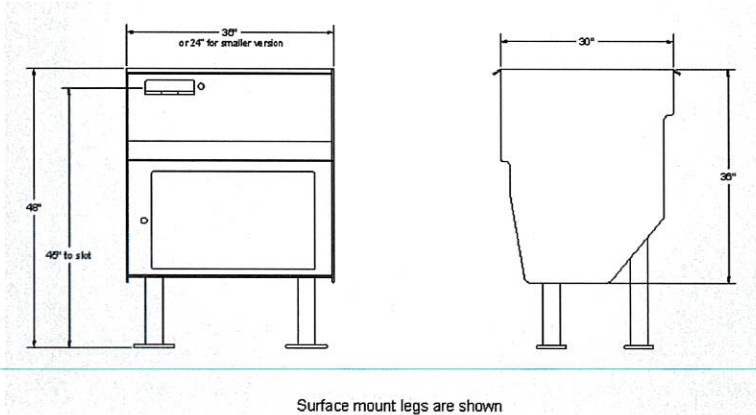

General Location of 24hr Box and Camera on site:



General description of utilities needed from site:

The Clerk will have access to and the right to use power and the internet at the Property for the security camera when said camera is active. Usage of the Property's internet will be kept to a minimum during business hours with video backup scheduled outside of those hours.