

ORDINANCE , 96, SERIES 2010

AN ORDINANCE VACATING A PORTION OF
MAIN STREET RIGHT-OF-WAY, GENERALLY LOCATED
AT 4217 MAIN STREET, TIMNATH, COLORADO

WHEREAS, the Town Council of the Town of Timnath, Colorado has been petitioned by the owner of property located at 4217 Main Street, Timnath, Colorado, to consider whether portions of property dedicated as "Main Street" in Timnath, Colorado should be vacated; and

WHEREAS, the area which has been dedicated for right-of-way is described on Exhibit A attached hereto; and

WHEREAS, it has been determined by the Town Council of the Town of Timnath, Colorado, following a public hearing on the matter, the said area described on Exhibit A is not needed for municipal purposes other than the retention of easements for public purposes; and

WHEREAS, C.R.S § 43-2-310, as amended, provides authority to the Town of Timnath to vacate portions of the right-of-way and to allow title to such vacated rights-of-way to vest in adjoining lands abutting said right-of-way;

NOW, THEREFORE, be it ordained by the Town Council of the Town of Timnath, County of Larimer, State of Colorado, to-wit:

That the description of the area in which the right-of-way to be vacated is located is described on Exhibit A. The right-of-way in the described area is hereby vacated subject to the Town retaining all rights which might otherwise exist to maintain utilities within such vacated right-of-way. Pursuant to C.R.S. § 43-2-303(3), all easements for sewer, gas, water, or similar pipelines and appurtenances, and for electric, telephone and other lines and appurtenances, are reserved.

INTRODUCED, MOVED, AND ADOPTED BY THE TOWN COUNCIL OF THE TOWN OF TIMNATH ON FIRST READING, ON MAY 19, 2010, AND SET FOR PUBLIC HEARING AND SECOND READING AT 7:00 P.M. ON JUNE 2, 2010 AT THE TIMNATH TOWN HALL, 4100 MAIN STREET, TIMNATH COLORADO AND ORDERED PUBLISHED BY TITLE THIS 19TH DAY OF MAY, 2010.

MOVED, SECONDED AND FINALLY ADOPTED ON SECOND READING FOLLOWING PUBLIC HEARING BY THE TIMNATH TOWN COUNCIL ON June 2, 2010.

TOWN OF TIMNATH

Donna Benson, Mayor

ATTEST:

Milissa McGuire, Town Clerk

Town of Timnath
1800 Goodman St
Timnath CO 80547

RECEPTION#: 20100041001, 07/19/2010 at
11:40:44 AM,
1 OF 2, R \$16.00 TD Pgs: 0
Scott Doyle, Larimer County, CO

4217 MAIN STREET

EXHIBIT A (1 of 1)

L4-10, B12, TIMNATH
SE 1/4 SEC. 34, T.7N., R.68W.

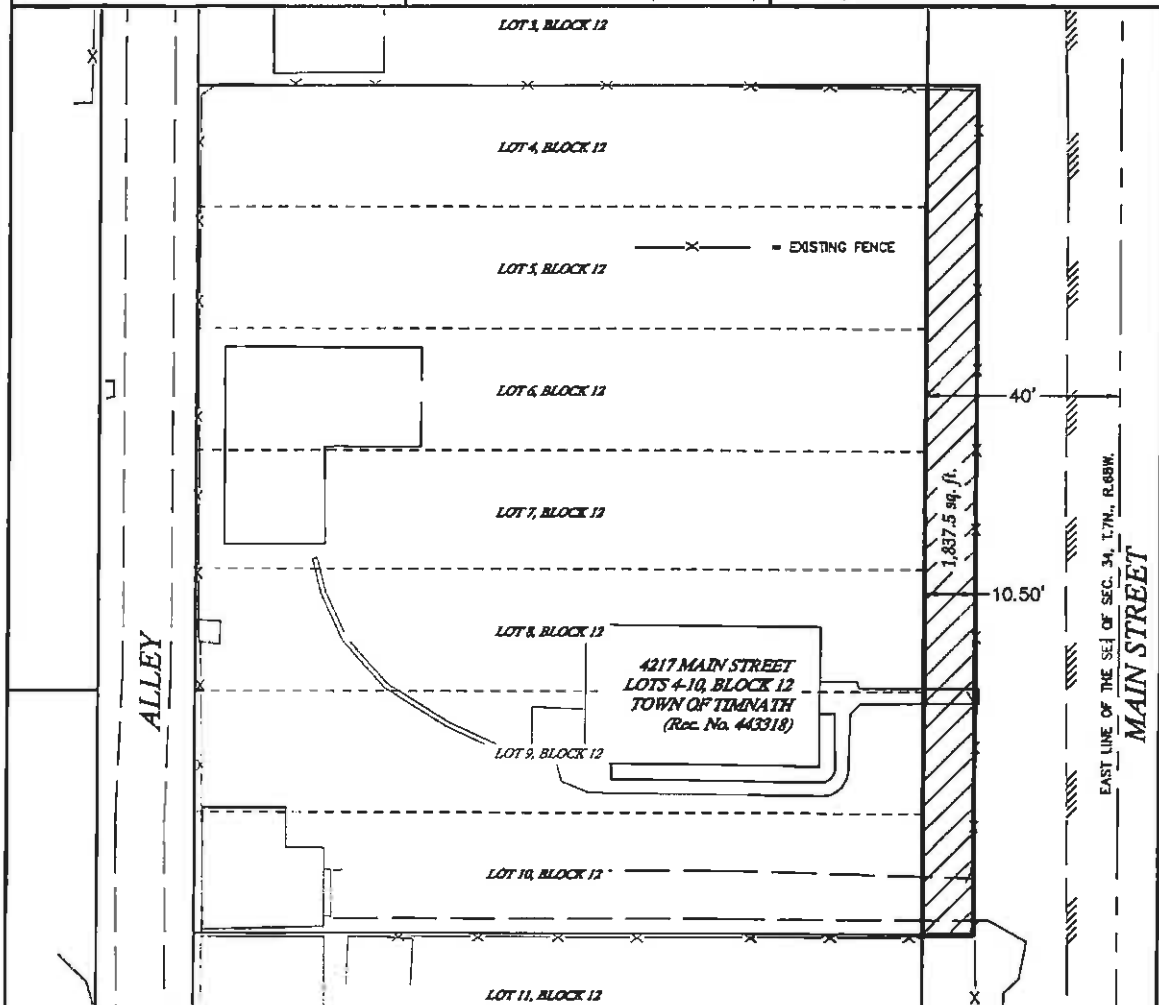

NOTE: This exhibit drawing is not intended to be a monumentalized land survey. It's sole purpose is as a graphic representation to aid in the visualization of the written property description which it accompanies. The written property description supersedes the exhibit drawing.

PROPERTY DESCRIPTION

A parcel of land being part of Main Street Right-of-Way as platted and shown on the plat entitled Map of Timnath, Larimer County, Colorado May 1920, recorded January 13, 1982 as Reception No. 443318 of the records of the Larimer County Clerk and Recorder, located in the Southeast Quarter (SE1/4) of Section Thirty-four (34), Township Seven North (T.7N.), Range Sixty-eight West (R.68W.) of the Sixth Principal Meridian (6th P.M.), Town of Timnath, County of Larimer, State of Colorado, and being more particularly described as follows:

The Westerly Ten and Fifty Hundredths (10.50) feet of said Main Street Right-of-Way being bounded on the North by the Easterly extension of the Northerly line of Lot Four (4), Block Twelve (12) of said Map of Timnath and being bounded on the South by the Easterly extension of the Southerly line of Lot Ten (10), Block Twelve (12) of said Map of Timnath.

Said parcel of land contains 1,837.5 sq. ft., more or less (±), and may be subject to any rights-of-way or other easements of record or as now existing on said described parcel of land.

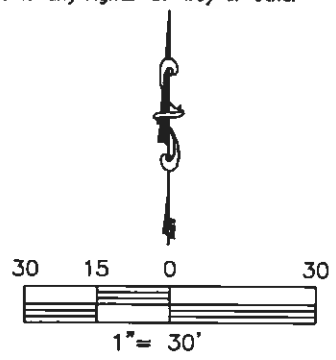
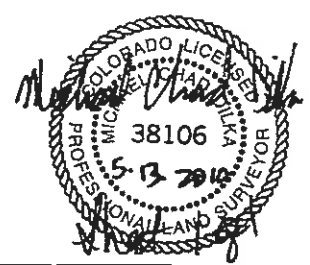

Michael Chad Dilka - On Behalf Of King Surveyors, Inc.
Colorado Licensed Professional Land Surveyor #38106



KING SURVEYORS, INC.
650 E. Garden Drive | Windsor, Colorado 80550
phone: (970) 686-5011 | fax: (970) 686-5821
www.kingsurveyors.com

PROJECT NO:2010170
DATE:05/13/2010
CLIENT:TOWN OF TIMNATH
DWG:2010170BASE
DRAWN:MCD CHECKED:MCD